

WHY USE QUIETURE PANELS?

These panels help improve the sound performance of wall assemblies, makes spaces quieter and adds energy efficiency. In short, you're using Quieture to create a quieter, more insulated space. Secure the panels tightly, seal any gaps, and layer other materials (like drywall or flooring) on top to finish the installation.

GENERAL PREPARATION BEFORE INSTALLATION

- **Storage:** Store the panels in a dry place, away from moisture or extreme weather conditions.
- **Where It's Used:** The panels are designed to be used behind drywall (in walls or ceilings).

*Quieture panels are also designed to be used on top of subfloors (beneath your flooring - see instructions below).

3-IN-1 SYSTEM



WALL & CEILING INSTALLATION

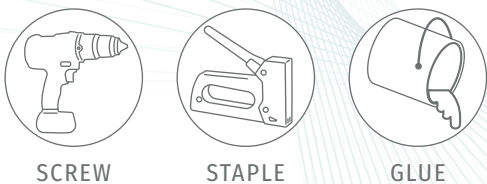

1. ATTACHING THE QUIETURE SOUNDBOARD PANELS

- **Fastening:** You secure the panels using staples or screws. You can also use a combination of methods using the screws/staples along with construction adhesive or acoustic sealants. Think of it as both gluing and stapling it into place. The staples should be long enough to go into the wall framing (studs) or floor structure.

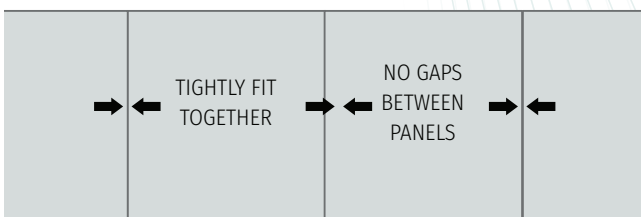

- **Tight Fit:** Ensure that the panels fit together tightly without any gaps. This helps them do their job better for sound control.

2. SEALING THE GAPS

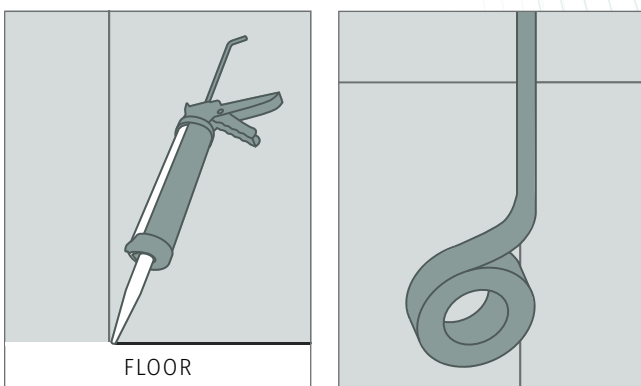

- **Caulking:** Any edges or seams between the boards (where they meet the floor, ceiling, or each other) need to be sealed with acoustical caulk. This specific caulk helps prevent sound from escaping or entering.
- **Taping:** You can also use aluminum foil tape with the panels to cover any seams between the panels. This ensures a solid barrier for both sound and air.

3. SAFETY PRECAUTIONS



- **Avoid Heat:** Keep Quieture Sound Board panels away from anything hot, like chimneys, heating units, or recessed lights unless they're certified safe to be near insulation. This prevents the material from being damaged by heat.

WALL & CEILING (OVER EXISTING DRYWALL):

1. REMOVE OBSTACLES

- Take off any light switch or outlet covers and make sure the wall is smooth.

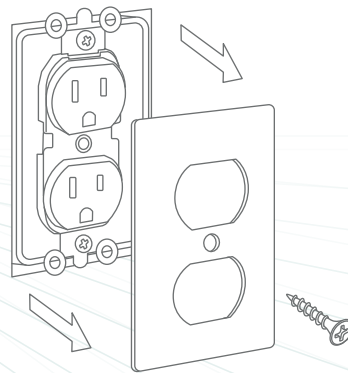

2. FASTENING THE BOARDS

- **Fastening the Boards:** Install the panels on the wall and attach them with staples or adhesive. Board orientation is subject to stud spacing. Make sure to staple into the wall's structure (studs). When installing Quieture with film, make sure the film side is facing the room. If stapling, make sure you use a 1/2" T50 staple or equivalent.

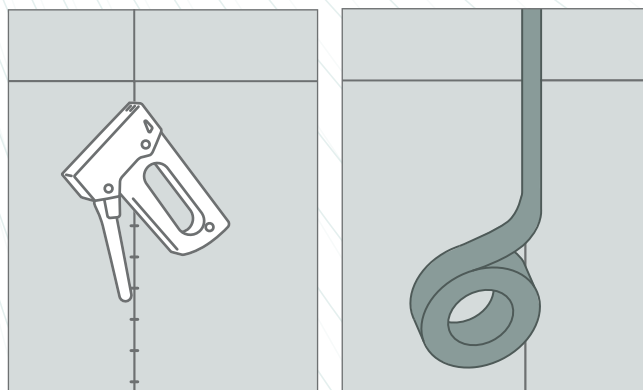

FLOOR INSTALLATION

1. CHECK SUBFLOOR

- Ensure the subfloor (the surface under your floor) is flat, clean, and structurally sound. All substrates must be flat within 1/8" over a 6' span, or 3/16" over a 10' span.



- **Always test for Moisture.** Ensure wood subfloors do not exceed 12% moisture content and concrete subfloors do not exceed 5lbs/1000sf/ of emissions on a calcium chloride test.
- We recommend the use of a Class I Vapor barrier when installing over a concrete slab.

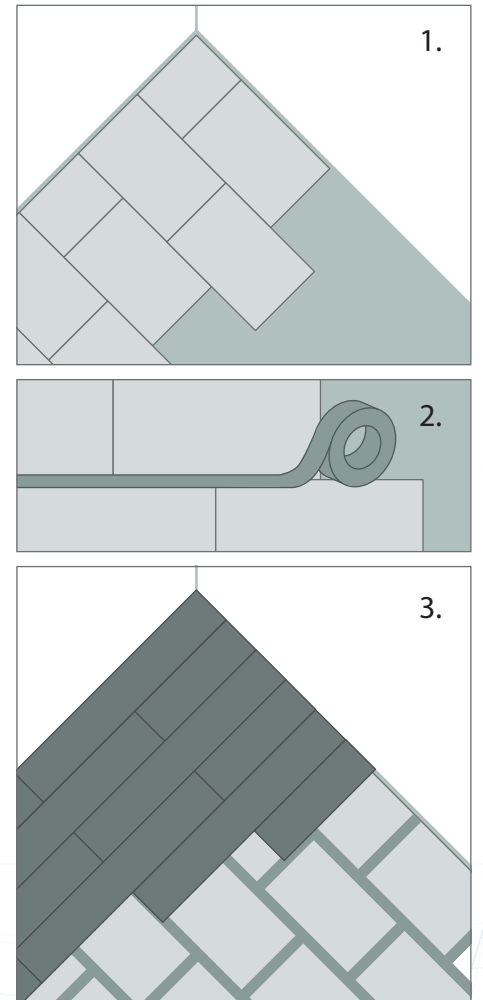

2. ATTACHING TO THE FLOOR

- You can either **float** the panels (just lay it down without attaching) or **glue** the panels to the subfloor, depending on the type of floor you're installing.
 - For floating floors exceeding 4mm in overall thickness, the panels can be floated (see figure 1).
 - For glue down or floors less than 4mm in overall thickness, the panels must be glued.
 - If floating the panels, a good quality tape (ie: Gorilla Tape) is required to tape the seams (see figure 2).
 - If gluing the panels, a good quality flooring adhesive is required to adhere the panels to substrate. The panels must be wet set. Please follow the flooring manufacturer's recommendations for adhering the floor covering to the panels.

3. MOISTURE RESTRICTIONS